

# ELECTRIC VESSEL PROPULSION (Chapter 11)

European Standard laying down Technical Requirements  
for Inland Navigation vessels (ES-TRIN)

August 2021



European Committee for drawing up  
Standards in the field of Inland  
Navigation



## DISCLAIMER

This FAQ document (hereinafter 'FAQ') reflects the interpretation of the European Committee for drawing up Standards in the field of Inland Navigation (CESNI) as regards the provisions of ES-TRIN, and it must not be considered or intended as a legally binding text for any reason whatsoever.

This FAQ shall be intended as a living document; its content could be modified or updated by CESNI, based on updates of the legislation, and according to CESNI's understanding on the matter as experience is gained.

CESNI, and thereby the Central Commission for the Navigation of the Rhine (CCNR), accept no responsibility for the recommendations, advice, statements and conclusions expressed or implied in this FAQ and give no warranty, representation or assurance with respect to the accuracy or validity of the same. Only the text of ES-TRIN is authentic in law.

Accordingly, in case of discrepancies between the content and interpretation of this FAQ and ES-TRIN, the provisions of ES-TRIN shall be applied.

## CONTACT

European Committee for drawing up Standards in the field of Inland Navigation (CESNI)  
Secretariat of the Central Commission for the Navigation of the Rhine  
2, Place de la République  
67082 Strasbourg  
France  
Email : [comite\\_cesni@cesni.eu](mailto:comite_cesni@cesni.eu)  
Web : [www.cesni.eu](http://www.cesni.eu)

All rights reserved

© August 2021

© Pictures: Adobe Stock, Fotolia, Pixabay, Shutterstock, CCNR

## TABLE OF CONTENTS

|   |    |
|---|----|
| <b>DISCLAIMER</b> .....   | 2  |
| <b>CONTACT</b> .....  | 2  |
| <b>TABLE OF CONTENTS</b> .....  | 3  |
| <b>PRELIMINARY REMARKS TO THE FAQ</b> .....   | 5  |
| <b>1 SCOPE OF APPLICATION OF CHAPTER 11 FOR DIESEL AND GAS-ELECTRIC PROPULSION SYSTEMS</b> .....  | 5  |
| Where does Chapter 11 cease to apply: “Special provisions applicable to electric vessel propulsion”?  | 5  |
| <b>2 DEFINITION OF THE ELECTRIC MAIN PROPULSION PLANT AND OF THE ELECTRIC AUXILIARY PROPULSION PLANT</b> .....  | 6  |
| What is the scope of application of these definitions?  | 6  |
| <b>3 CHAPTER 11: REDUNDANCY REQUIREMENTS</b> .....  | 6  |
| Does Chapter 11 require redundant propulsion systems?   | 6  |
| <b>4 APPLICATION OF ARTICLE 10.02(1)</b> .....  | 7  |
| Is Article 10.02 be applied when applying Chapter 11?   | 7  |
| <b>5 APPLICATION OF ARTICLE 6.02</b> .....  | 7  |
| Is Article 6.02 to be applied when applying Chapter 11?   | 7  |
| <b>6 DESIGN OF THE PROPULSION SYSTEM</b> .....  | 8  |
| What possibilities does the provision confer for the design of the propulsion system?   | 8  |
| <b>7 HYBRID SYSTEMS</b> .....   | 9  |
| Are hybrid systems permitted? How should they be designed?  | 9  |
| <b>8 REQUIREMENTS ON AN ELECTRIC MAIN PROPULSION PLANT WITH ONLY ONE ELECTRIC PROPULSION MOTOR</b> .....  | 10 |
| Does the electric main propulsion plant need to be designed to be redundant?  | 10 |
| <b>9 REACHING THE BERTH UNDER ALL CONDITIONS</b> .....  | 11 |
| What does “under all conditions” mean?  | 11 |
| Does Article 11.01(4) relate to generators?   | 12 |
| <b>10 MALFUNCTION OF THE ELECTRIC VESSEL PROPULSION SYSTEM/IMPAIRED FUNCTIONING OF EMERGENCY SYSTEMS</b> .....  | 13 |
| How can it be demonstrated that a malfunction of the electric vessel propulsion system cannot impair the functioning of the emergency systems?  | 13 |
| <b>11 CONNECTION/SHUTDOWN OF A GENERATOR WITHOUT INTERRUPTION</b> .....   | 14 |
| Is it generally possible to switch a generator on or off without interrupting propeller propulsion, when there is a strict separation between the propulsion systems and only one generator per propeller is installed? | 14 |
| <b>12 ELECTRIC PROPULSION MOTORS</b> .....  | 14 |
| What is meant by “brief overloads”?   | 14 |

|    |   |    |
|----|---|----|
| 13 | HARMONICS.....  | 15 |
|    | Should there not be specific limits e.g. for total harmonic distortion in that regard?  | 15 |
| 14 | MINIMUM REQUIREMENTS ON THE INSULATION OF THE WINDINGS .....  | 15 |
|    | What is this provision for?   | 15 |
| 15 | PROTECTION OF EXCITATION CIRCUITS AGAINST SHORT-CIRCUITS .....  | 16 |
|    | What is meant by the term “excitation circuits”?  | 16 |
| 16 | DISPLAYS.....   | 17 |
|    | Why is the information to be displayed not specified in detail?   | 17 |
|    | Is it enough to display this information on the switchboard?  | 17 |
| 17 | ON-SITE OPERATION.....  | 17 |
|    | How could on-site operation be achieved?  | 17 |
| 18 | OPERATING CONDITIONS AND FUNCTIONING .....  | 18 |
|    | “Operating conditions and functioning” must be clarified. Alarms and malfunctions are recorded on most vessels. Is that sufficient? | 18 |
|    | Several propulsion components are able to record their own data. Is this sufficient or is central data recording needed?            | 18 |
| 19 | DIFFERENTIAL PROTECTION OR EQUIVALENT PROTECTIVE DEVICE .....   | 19 |
|    | What is being protected here?   | 19 |
|    | Does the triggering result in the motor being unintentionally shut down?  | 19 |
| 20 | WINDING TEMPERATURE MONITORING SYSTEM.....  | 19 |
|    | What features must the winding temperature monitoring system have? Are simple alarm initiators sufficient?                          | 19 |
| 21 | PROTECTION AGAINST HARMFUL BEARING CURRENTS .....   | 20 |
|    | What kind of protection does this requirement offer?  | 20 |

## PRELIMINARY REMARKS TO THE FAQ

This FAQ applies to all vessels but account needs to be taken of the additional requirements applicable to passenger vessels (Chapter 19 of ES-TRIN).

### 1 SCOPE OF APPLICATION OF CHAPTER 11 FOR DIESEL AND GAS-ELECTRIC PROPULSION SYSTEMS

Where does Chapter 11 cease to apply: “Special provisions applicable to electric vessel propulsion”?

---



The requirements of Chapter 11 apply **to the electrical part of a diesel and gas-electric propulsion system.**

The requirements arising from the use of particular fuels, are mentioned in other chapters (e.g. in Chapter 8 for diesel fuel, in Chapter 30 in conjunction with annex 8 for LNG, in Chapter 10 on explosion protection).

These requirements also apply to the requirements in Chapter 11.

## 2 DEFINITION OF THE ELECTRIC MAIN PROPULSION PLANT AND OF THE ELECTRIC AUXILIARY PROPULSION PLANT

*“electric main propulsion’ an electric vessel propulsion which is applied to achieve the manoeuvrability laid down in Chapter 5;”.*

*“electric auxiliary propulsion’ an additional electric vessel propulsion of a craft that is not an electric main propulsion;”.*

### What is the scope of application of these definitions?

---

The terms “electric main propulsion plant” and “electric auxiliary propulsion plant” are purely definitions and apply to Chapter 11.

The requirements for such propulsion systems are defined in the following articles of Chapter 11.

*References: ES-TRIN, Article 11.00(3) and (4).*

## 3 CHAPTER 11: REDUNDANCY REQUIREMENTS

### Does Chapter 11 require redundant propulsion systems?

---

**No.** The safety requirement in Articles 11.01 to 11.04 and 11.08 is purely the ability to move under the vessel’s own power. To that extent it may be necessary for individual components of the electric vessel propulsion system (such as power electronics components) to be designed to be redundant.

Admittedly, Chapter 11, Article 11.01(1)(a) does also require two power sources. But these are independent of the number of propulsion systems (see FAQ 6 for the propulsion systems’ design). To that extent, this provision is comparable with the provision in Article 6.02.

The provisions of Article 11.01(7) contain no obligation to equip a vessel with two independent propulsion systems. All that they define is when two electric propulsion systems are deemed to be independent.

For example, Article 19.07 contains a mandatory installation obligation.

*References: ES-TRIN, Articles 11.01 to 11.04, 11.08 and 19.07.*



## 4 APPLICATION OF ARTICLE 10.02(1)

*“Where craft are fitted with an electrical installation, that installation shall have at least two power sources in such a way that where one power source fails the remaining source is able to supply the consumer equipment needed for the safe operation for at least 30 minutes.”*

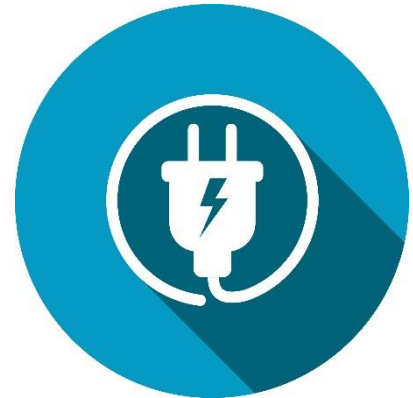

### Is Article 10.02 be applied when applying Chapter 11?

**Yes.** Article 10.02(1) requires two independent energy sources for the on-board power supply.

If an electric vessel propulsion system as defined in Article 11.00(2) is supplied via the on-board network, the provision in Article 11.01(1) pertaining to the power generation units or power sources refers to the energy sources referred to in Article 10.02(1). In addition, Article 11.06(2) is to be observed and the requirements in Chapter 11 for movement under the vessel's own power complied with.

*References: ES-TRIN, Article 10.02(1), Article 11.00(2), Article 11.01(1) and Article 11.06(2).*

*Remark: this FAQ applies to all vessels but account needs to be taken of the additional requirements applicable to passenger vessels (Chapter 19).*

## 5 APPLICATION OF ARTICLE 6.02

*“If the steering apparatus has a powered drive unit, a second independent drive unit or an additional manual drive shall be present. In case of failure or malfunction of the drive unit of the rudder system, the second independent drive unit or the manual drive has to be in operation within 5 seconds.”*

### Is Article 6.02 to be applied when applying Chapter 11?

**Yes.** Article 6.02(1) requires a second independent drive unit or a manual drive.

Under article 10.02(3), article 6.02(1) applies independently of article 10.02(1), and thus also independently of the provisions of chapter 11.

*References: ES-TRIN, Article 06.02(1) and Article 10.02(1) and (3).*

## 6 DESIGN OF THE PROPULSION SYSTEM

What possibilities does the provision confer for the design of the propulsion system?

---

The principle can be illustrated by means of a sketch.

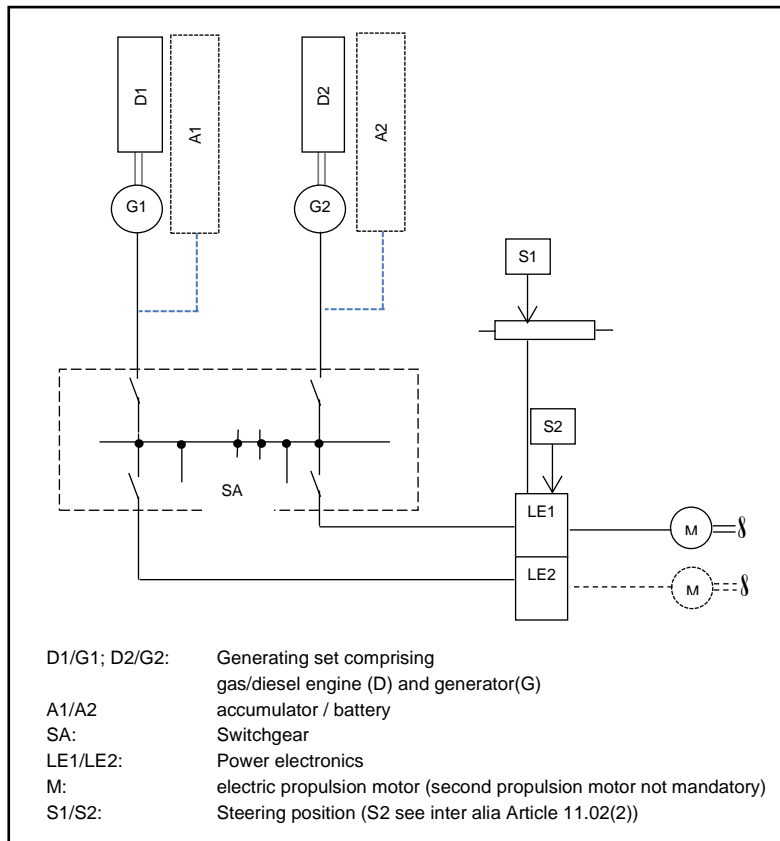

*Reference: ES-TRIN, Article 11.01(1).*

*Remark: this FAQ applies to all vessels but account needs to be taken of the additional requirements applicable to passenger vessels (Chapter 19).*



## 7 HYBRID SYSTEMS

Are hybrid systems permitted? How should they be designed?



**Yes.** Hybrid systems are systems which combine an electrical power source (generator set, fuel cell, accumulators, etc.) with another power source.

The following diagrams describes two possible hybrid architectures as examples:

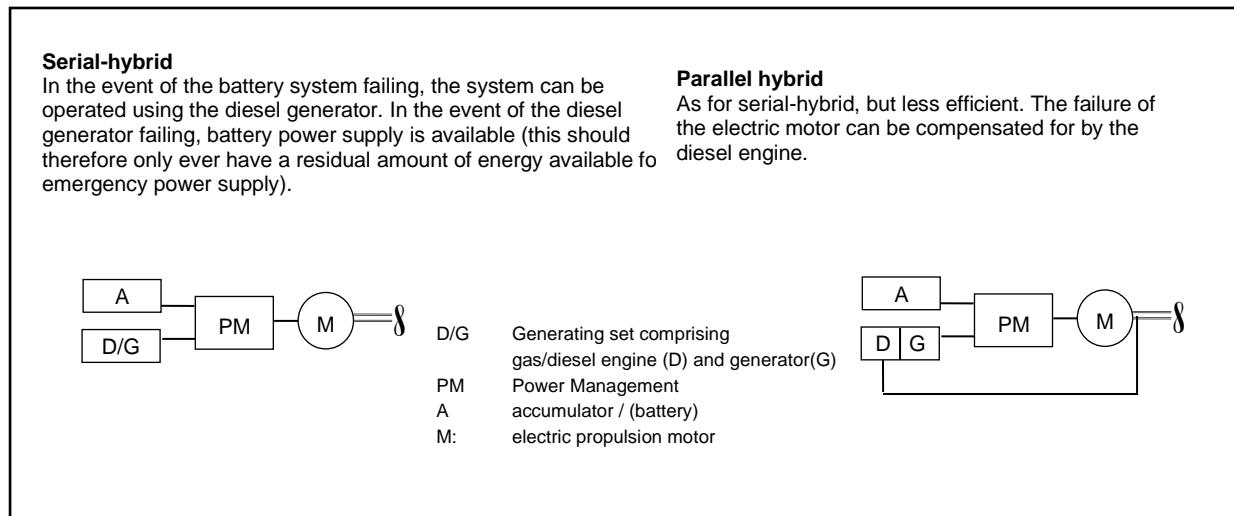

Reference: ES-TRIN, Article 11.01(1).

## 8 REQUIREMENTS ON AN ELECTRIC MAIN PROPULSION PLANT WITH ONLY ONE ELECTRIC PROPULSION MOTOR

### Does the electric main propulsion plant need to be designed to be redundant?

**No, the main propulsion plant does not need to be designed to be redundant.** Both Articles 11.01(1)(c) and (2) clearly require only one electric propulsion motor. Article 11.01(1)(a) only requires two power sources.

Article 11.02 additionally requires the ability to move under the vessel's own power in the event of a power electronics or control and regulation failure.

Depending on the design, this might require power electronics or control and regulation redundancy.

See also the diagram in FAQ 6.

*References: ES-TRIN, Article 11.01(1) and (2), and Article 11.02.*

## 9 REACHING THE BERTH UNDER ALL CONDITIONS

### What does “under all conditions” mean?

The battery / accumulator **must retain sufficient energy** (or else the capacity of all the batteries and accumulators together must be sufficiently large) **that it is possible to operate until a charging station is reached.** This reserve is referred to here as **residual capacity**. In order to be sure of reaching a charging station, it follows that a fall in capacity must trigger a timely warning (alarm) before the residual capacity limit is reached.

Calculating this residual capacity first requires an estimate of the maximum distances to be covered with the accumulator until it can be recharged in case of doubt. **Reaching a berth under all circumstances is accepted if there is a guaranteed ability to move under its own power for 30 minutes at 6.5 km/h.**

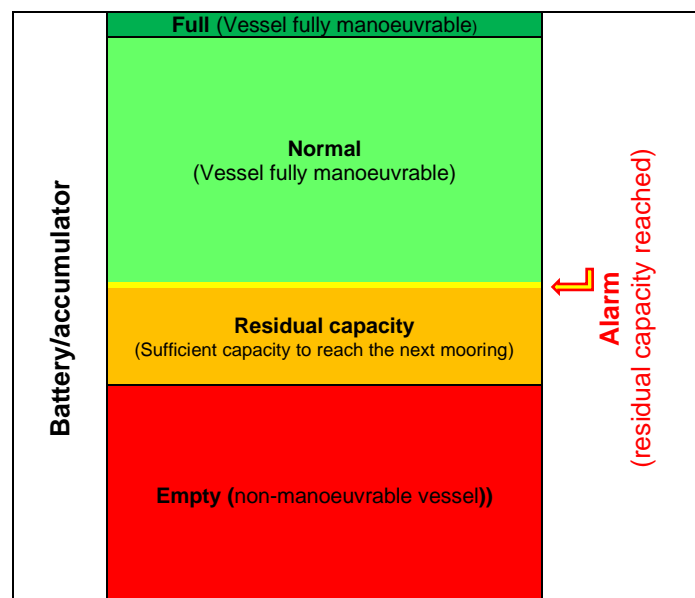

- *Example 1*  
Freight transport (variably adjustable residual capacity, universally applicable)

One could imagine considering all known moorings passed en route. The longest distance between two of these moorings would then be halved. The residual capacity then needs to be sufficient to be sure of bridging this distance.

- *Example 2*  
Passenger vessel (variably adjustable residual capacity, universally applicable)

One could imagine considering all the berths associated with a tour. One would then have to select the greatest distance between the relevant berths. The residual capacity then needs to be sufficient to be sure of bridging half this distance.

- *Example 3*  
General solution navigation area (adjustable, fixed, residual capacity restricted as to navigation area)

One looks at the most reliable solution possible starting from any point to an intended mooring/berth. That means the lowest average speed of travel, and the time and distance in which one can be sure of reaching a mooring/berth. The residual capacity then has to be calculated for these conditions so that it is certain that the intended mooring/birth can be reached.

*!!! Note: The restriction to one navigation area is to be mentioned in the inland navigation vessel certificate.*

- *Example 4*  
General solution zone 3 International (ES-TRIN)

Approach identical to example 3, the only difference being is that the conditions have to be applied to the entire zone 3 international area. Particular attention would have to be paid to the conditions on the Lower Danube and Middle Rhine.

## Does Article 11.01(4) relate to generators?

**This article does not relate to generators.** It refers to batteries or accumulators feeding the electric propulsion motors (comparable requirements for diesel engine tanks are contained in Article 8.05(13) ES-TRIN).

*Reference: ES-TRIN, Article 11.01(4).*

## 10 MALFUNCTION OF THE ELECTRIC VESSEL PROPULSION SYSTEM/IMPAIRED FUNCTIONING OF EMERGENCY SYSTEMS

### How can it be demonstrated that a malfunction of the electric vessel propulsion system cannot impair the functioning of the emergency systems?

---

An appropriate method of corroboration is to be chosen depending on the system's complexity.

In the case of a simple system configuration (e.g. completely separate powertrains both physically and electrically (energy source (engine, power supply units, battery/accumulator) including power electronics), transmission, shaft, propeller, etc., as well as separate emergency power supply) it is obvious that the subsystems are incapable of influencing one another and that the functioning of the emergency systems cannot therefore be impaired.

In the case of a more complex system configuration (energy sources shared by a number of power consumers, load-dependent switching on and off of a number of energy sources, networked power management etc.) the corroboration can be provided, for example, by an FMEA-S risk study, which in any case, in addition to electro-technical aspects of the system design, also has to incorporate mechanical component and sensor failure.

This would have to entail particular attention being paid to a reliable and dependable way of separating the components required in order for the emergency systems to operate from the defective system components.

For propulsion systems with a single electric motor, a single shaft and a single propeller, the risk assessment may be restricted to duplicated parts of the system (i.e. energy sources).

*Reference: ES-TRIN, Article 11.01(6).*

## 11 CONNECTION/SHUTDOWN OF A GENERATOR WITHOUT INTERRUPTION

Is it generally possible to switch a generator on or off without interrupting propeller propulsion, when there is a strict separation between the propulsion systems and only one generator per propeller is installed?

---

**Yes. This requirement must apply to all generators!**

Note: We are talking about switching on and off without interrupting the main propulsion system.

For example: a vessel with four 250 kW propulsion systems. In this case, the generators for the propulsion systems are individually switched on and off, depending on the area of navigation (inter alia, to save fuel).

To Article 11.01(2), the electric main propulsion system consists of two generating sets. If one of these power supply units is the generator in question, a battery/accumulator must also be available. On this basis, the provision can be complied with.

*Reference: ES-TRIN, Article 11.02(4).*

## 12 ELECTRIC PROPULSION MOTORS

What is meant by “brief overloads”?

---

One acceptable definition of “Brief overloads” is **a 110% load for a 15-minute period.**

*Reference: ES-TRIN, Article 11.03(1).*

## 13 HARMONICS

Should there not be specific limits e.g. for total harmonic distortion in that regard?

---

The laying down of single minimum values would approximate too closely to building or classification society regulations. Therefore, no such value was laid down.

*Reference: ES-TRIN, Article 11.03(2).*

## 14 MINIMUM REQUIREMENTS ON THE INSULATION OF THE WINDINGS

What is this provision for?

---

**The insulation of the windings must withstand the overvoltages to prevent a short circuit.** High peak voltages (overvoltages) can occur, especially during manoeuvres and switching operations, resulting, for example, in high wiring temperatures capable of damaging the insulation. This is to be avoided.

The European Standard EN 60034-25 : 2013 can be used as guideline for the values for maximum permissible overvoltages.

*Reference: ES-TRIN, Article 11.03(3).*





## 15 PROTECTION OF EXCITATION CIRCUITS AGAINST SHORT-CIRCUITS

### What is meant by the term “excitation circuits”?

The excitation circuit is the power circuit through which current flows through a motor’s excitation windings. The mobile anchor, the rotor as a counterpoise carries the anchor winding and a commutator or reversing switch ensures the regular reversal in polarity of the direction of the current, to ensure continuous turning (see diagram).

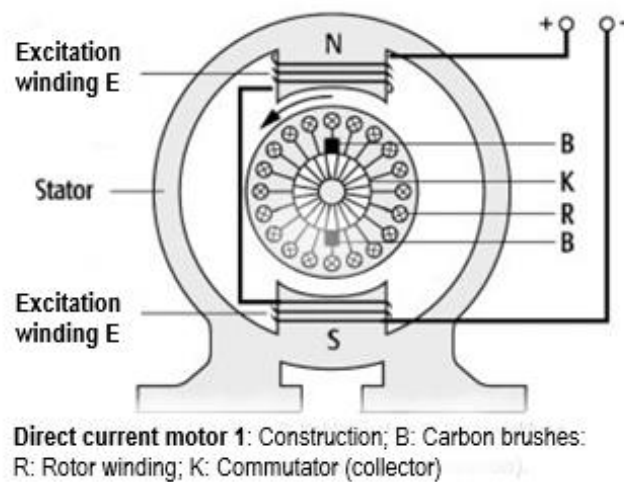

Source of the diagram: <https://www.spektrum.de/lexikon/physik/gleichstrommotor/5952> as at 6.2.2020

*Remark 1:* There are also permanently excited motors with magnets and no excitation coil. Not all motors look like the one in the diagram.

*Remark 2:* Coils (windings) are insulated to protect against short-circuit. How this is achieved is answered in FAQ 13.

*Reference: ES-TRIN, Article 11.04(4).*

## 16 DISPLAYS

Why is the information to be displayed not specified in detail?

Is it enough to display this information on the switchboard?

---

No restrictions should be placed on the manufacturers in this regard. The installations might be set up in different ways and could thus require different displays.

In general, three operating states are important: on, off, error. However, other operating states could be displayed, for example, remote maintenance or reduction in power, etc.

Restricting the location of a display (switchboard) to one place is therefore not effective.



*Reference: ES-TRIN, Article 11.05(1).*

## 17 ON-SITE OPERATION

How could on-site operation be achieved?

---

On-site operation (ie power control and direction of rotation of the propeller) can be effected, for example, from the power electronics control cabinet.

*Reference: ES-TRIN, Article 11.05(2).*



## 18 OPERATING CONDITIONS AND FUNCTIONING

“Operating conditions and functioning” must be clarified. Alarms and malfunctions are recorded on most vessels. Is that sufficient?

Several propulsion components are able to record their own data. Is this sufficient or is central data recording needed?

---

No restrictions should be placed on the manufacturers for this provision. The installations might be set up in different ways and could therefore function differently, so that different parameters need to be recorded.

The key aspect here is safety. Errors must be easy to understand. In the event of such a specification being made, the inspection body would be disadvantaged in other cases.

*Reference: ES-TRIN, Article 11.05(3).*



## 19 DIFFERENTIAL PROTECTION OR EQUIVALENT PROTECTIVE DEVICE

### What is being protected here?

---

The principle behind the differential protection relay is based on Kirchhoff's 1st Law.

Accordingly, the sum of all currents flowing into and out of a network node, namely in a part within an item of equipment that is of interest, must at all times be zero.

A failure in a cable, busbar or transformer gives rise to unwanted fault currents, which flow between a phase and earth. These fault currents are detected by the sum of the instantaneous values. If a threshold value setting is exceeded, the protection kicks in.

### Does the triggering result in the motor being unintentionally shut down?

---

Theoretically this could happen, but the triggering of other safety mechanisms as well can result in the motor being shut off. In large part, this is to be avoided by the provision in Article 11.07(1).

The automatic switching off of the propulsion system must be restricted to malfunctions that would result in significant damage within the system.

Furthermore (b) does not require the use of differential protection. (b) provides for the possibility of alternative protection if the equivalent protection objective is achieved.

*Reference: ES-TRIN, Article 11.07(5)(b).*

## 20 WINDING TEMPERATURE MONITORING SYSTEM

### What features must the winding temperature monitoring system have? Are simple alarm initiators sufficient?

---

This monitoring can be composed of a more complex system for testing the functions, but also of a simple alarm initiator.

*Reference: ES-TRIN, Article 11.07(5)(c).*

## 21 PROTECTION AGAINST HARMFUL BEARING CURRENTS

### What kind of protection does this requirement offer?

---

The modern 2-point converters in IGBT technology (insulated-gate bipolar transistor) generate an output voltage with very steep voltage edges.

The steep voltage flanks cause bearing currents due to parasitic capacities in the engine.

These bearing currents can significantly shorten the lifespan of engine mounts..



*Reference: ES-TRIN, Article 11.07(6)(c).*

